

DIMENSIONS			
A	B	C	FIXING CTC
300	100	45	270
400	120	60	370
500	120	60	470
600	150	60	570
700	150	60	670
800	150	60	770
900	150	80	870

	Drawing <b>M09</b>
	Date <b>24/05/2022</b>
	Scale <b>1:2</b>

Grub Screw

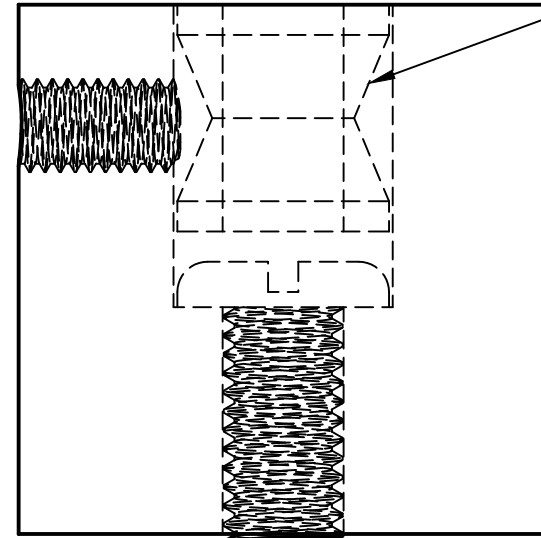
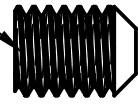

Brass Ferrule

Handle Stand



M8 Bolt

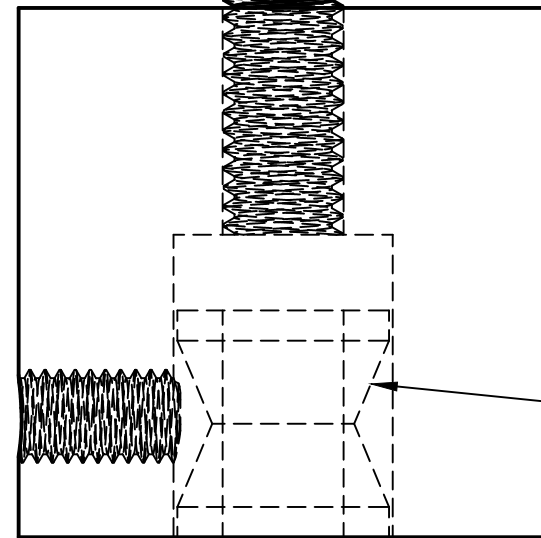

Threaded Handle Stand

Brass Ferrule

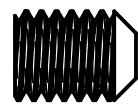

**Installation Instructions**

IMPORTANT! Mark and drill door from both sides.

Cut bolt to required length. Allow 30mm longer than door thickness.

Screw stands together through door.

Place handle on stand, inserting Ferrules into stand.

Tighten Grub Screws



Drawing  
Entrance Handle Fixing B2B  
Date  
2/02/2023  
Scale  
2:1

<b>Installation Instructions</b>
IMPORTANT! Mark and drill door from both sides.
Cut bolt to required length. Allow 15mm longer than door thickness.
Screw stands from behind to door.
Place handle on stand, inserting Ferrules into stand.
Tighten Grub Screws

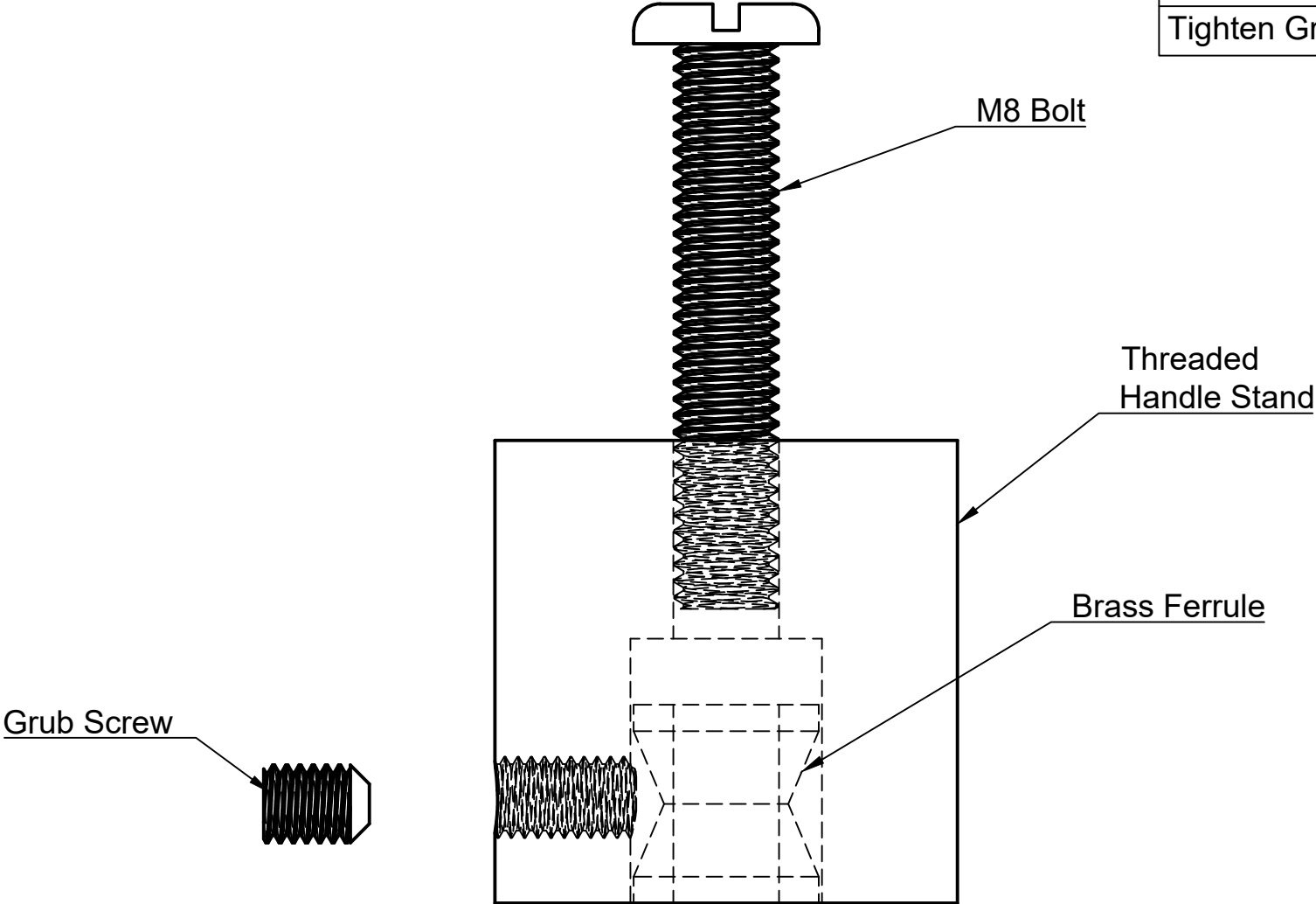

Drawing <b>Entrance Handle Rear Fixing</b>
Date <b>2/02/2023</b>
Scale <b>2:1</b>

**Installation Instructions**

Screw stand to door.

Place handle on stand, inserting Ferrules into stand.

Tighten Grub Screws

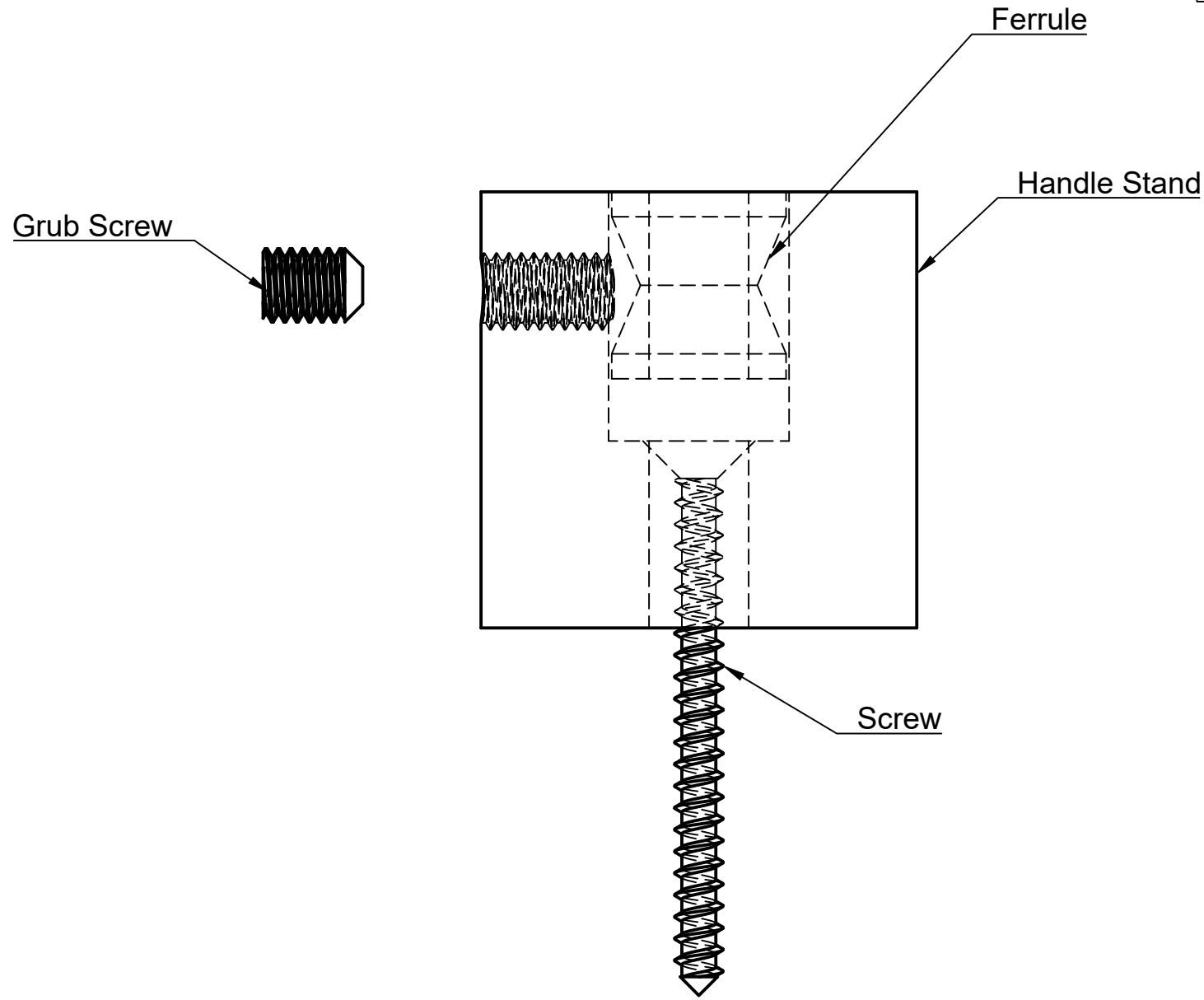

Drawing	Entrance Handle Surface Fixing
Date	2/02/2023
Scale	2:1

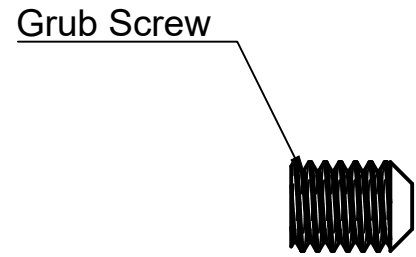

Brass Ferrule

Handle Stand

Plastic/Rubber Washer  
(only for glass fixing)

Plastic/Rubber Washer  
(only for glass fixing)

Plastic/Rubber Washer  
(only for glass fixing)

Threaded Handle Stand

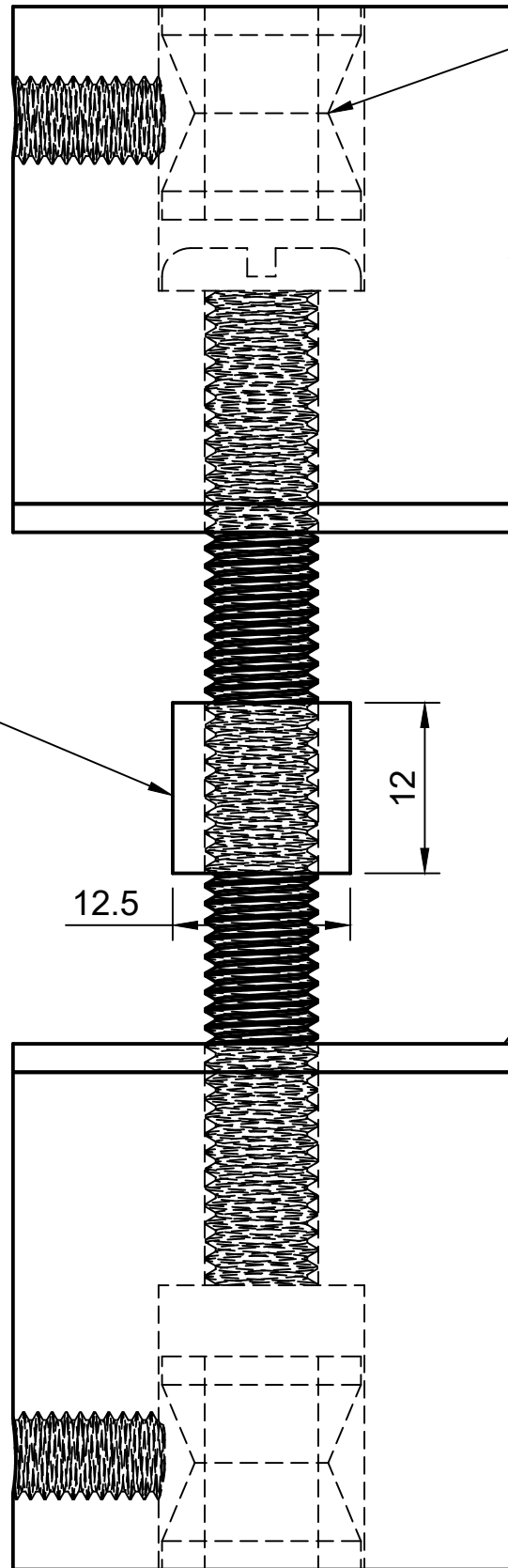

### Glass Fixing Installation Instructions

- Drill 13mm holes for bolt and plastic/rubber washer
- Check dimensions carefully prior to drilling holes, each handle in our range is different.
- Cut bolt to required length. Allow 30mm longer than the door thickness.
- Screws stands together through door, including the plastic/rubber washers as shown in the drawing.
- Place handle on stand, inserting the Ferrules into the stand.
- Tighten Grub Screws.
- Glass Fixing Kits with Rubber/Plastic parts are sold seperately
- Rear Fixing Studs are available when only one side requires a handle.



Drawing  
Entrance Handle Glass Fixing B2B  
Date  
30/08/2024  
Scale  
2:1