

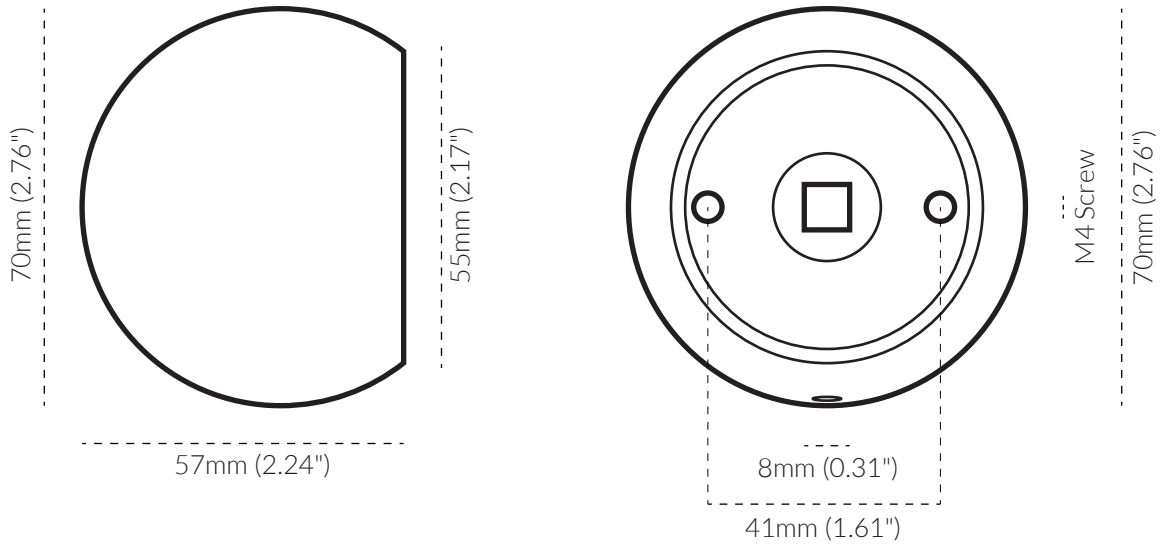







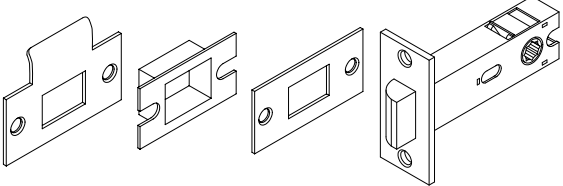
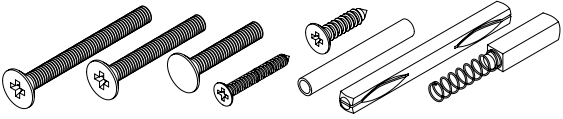

# SPHERE PASSAGE SET

## TECH SPEC

### SPECIFICATIONS



FINISH	SKU	FIXINGS ALSO INCLUDED
 Natural Brass	<b>4226-US4</b>	<ul style="list-style-type: none"> <li>- 1x Striker Plate</li> <li>- 1x Latch Plate</li> <li>- 1x Latch Pocket</li> <li>- 1x Latch</li> <li>- 2x M4 * 15mm Screw</li> <li>- 2x M4 * 25mm Screw</li> <li>- 2x M4 * 35mm Screw</li> <li>- 4x 2ga Screw</li> <li>- 8x 1ga Self-tapping Screw</li> <li>- 2x M4 Screw Extension</li> <li>- 1x M8 Pin</li> <li>- 2x M8 Spring Pin</li> </ul>  
 Aged Brass	<b>4226-AB</b>	
 Tumbled Brass	<b>4226-TB</b>	
 Bronze	<b>4226-BR</b>	
 Brushed Nickel	<b>4226-BN</b>	
 Tumbled Nickel	<b>4226-TN</b>	
 Matte Black	<b>4226-US19</b>	

### CARE INSTRUCTIONS

Wipe with damp cloth and avoid using any chemicals.



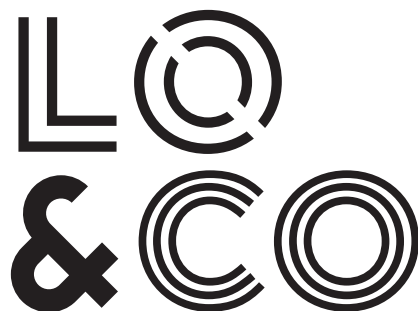

## SPHERE PASSAGE SET

### INSTALLATION INSTRUCTIONS

#### STEP 3 - INSTALLING THE FITTING PLATES

- 3.1. Loosen the grub screw on each doorknob to remove and expose the fitting plates.
- 3.2. Insert the spindle halves (spring end first) into each fitting plate, then position them through the latch follower.
- 3.3. While the fitting plates are in position, mark the left and right fixing holes on both sides of the door face using the holes in the plates as a template.
  - **Tip:** Ensure the grub screw holes on both fitting plates are aligned vertically and facing downward to allow correct doorknob orientation in Step 4.
- 3.4. Remove the plates and drill the marked holes using a 6mm drill bit.
  - **Tip:** Drill halfway from one side, then complete the hole from the opposite side to ensure proper alignment.

- 3.5. On the outward-facing side of the door, attach the two screw extensions to the fitting plate using the two flat-end 15mm M4 screws. Reinsert the fitting plate into the latch.
- 3.6. On the inward-facing side, align the second fitting plate and connect both sides by securing the 25mm M4 screws into the screw extensions.
  - For doors up to 45mm thick, the included 35mm M4 screws may be used if required.
  - Optional: Use the provided self-tapping screws in the remaining two holes to prevent the lever handle from loosening over time.
- 3.7. Position the metal clips over the top of each fitting plate; these sit between the fitting plate and the doorknob to help prevent movement and provide added stability once the knobs are secured.

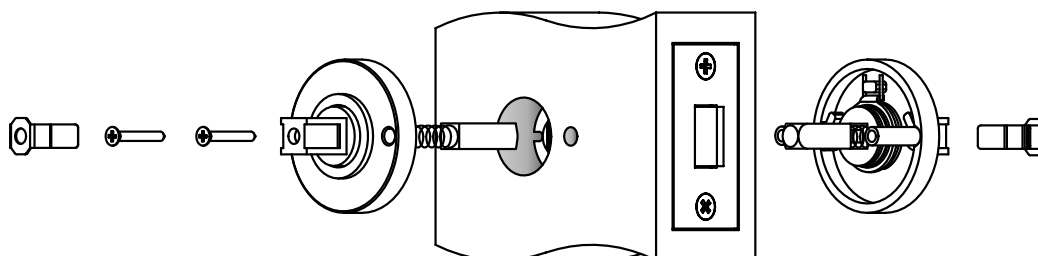

#### STEP 4 - FITTING THE DOORKNOBS

- 4.1. With the grub screw hole positioned at the bottom, fit the doorknob over the fitting plate and tighten the grub screw.
  - **Note:** You may need to adjust the doorknob slightly forward or backward to locate the grub screw hole.
- 4.2. Repeat on the other side of the door.
- 4.3. Check the knobs are secure by gently pulling away from the door face. If a knob comes loose, realign and tighten the grub screw further. Once correctly installed, the knob will not detach.

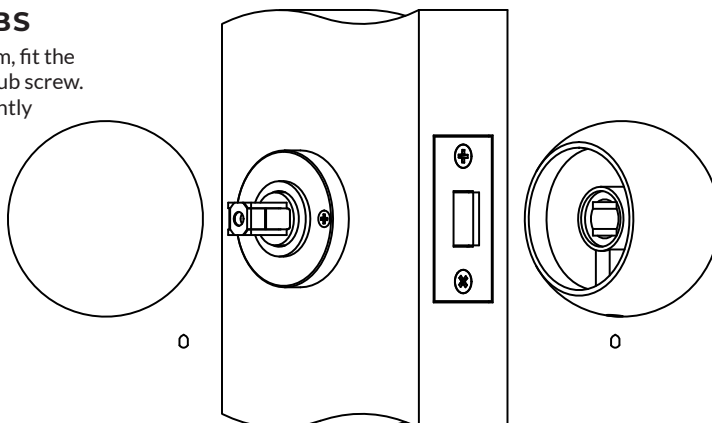

#### NOTES

- o Striker plates are designed to receive contact from the latch and will naturally show wear over time. On darker finishes applied over a brass base, this wear may become more visible as the underlying metal is exposed. This is not considered a fault but a normal part of their function.
- o We recommend engaging a professional installer to fit your hardware for optimal results.

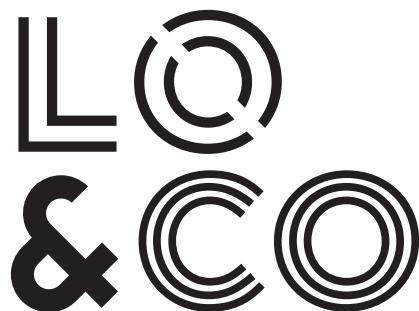

## SPHERE PASSAGE SET

### INSTALLATION INSTRUCTIONS

#### STEP 5 - INSTALLING THE STRIKER PLATE

- 5.1. Gently close the door and mark where the latch bolt contacts the frame.
- 5.2. Position the striker plate over the mark, ensuring proper alignment with the latch, and trace the outline.
- 5.3. Drill a hole in the door frame at the latch mark using a bit that matches the latch bolt.
- 5.4. Chisel a recess so the striker plate sits flush with the frame.
- 5.5. Predrill the screw holes and secure the plate with the provided screws.
- 5.6. Open and close the door to ensure the latch engages smoothly. Adjust if necessary.

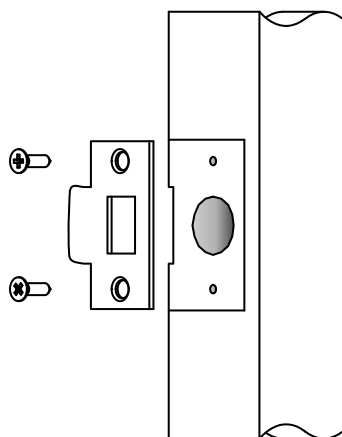

#### NOTES

- o Striker plates are designed to receive contact from the latch and will naturally show wear over time. On darker finishes applied over a brass base, this wear may become more visible as the underlying metal is exposed. This is not considered a fault but a normal part of their function.
- o We recommend engaging a professional installer to fit your hardware for optimal results.



# SPHERE PASSAGE SET

## INSTALLATION INSTRUCTIONS

\*SUITS DOORS  
32-45MM THICK

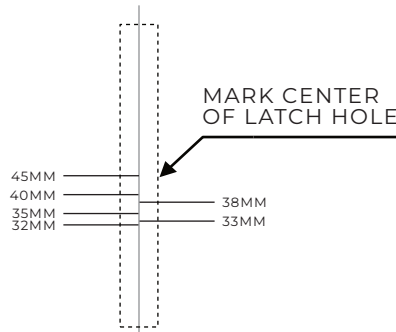

FOLD HERE

FOLD HERE

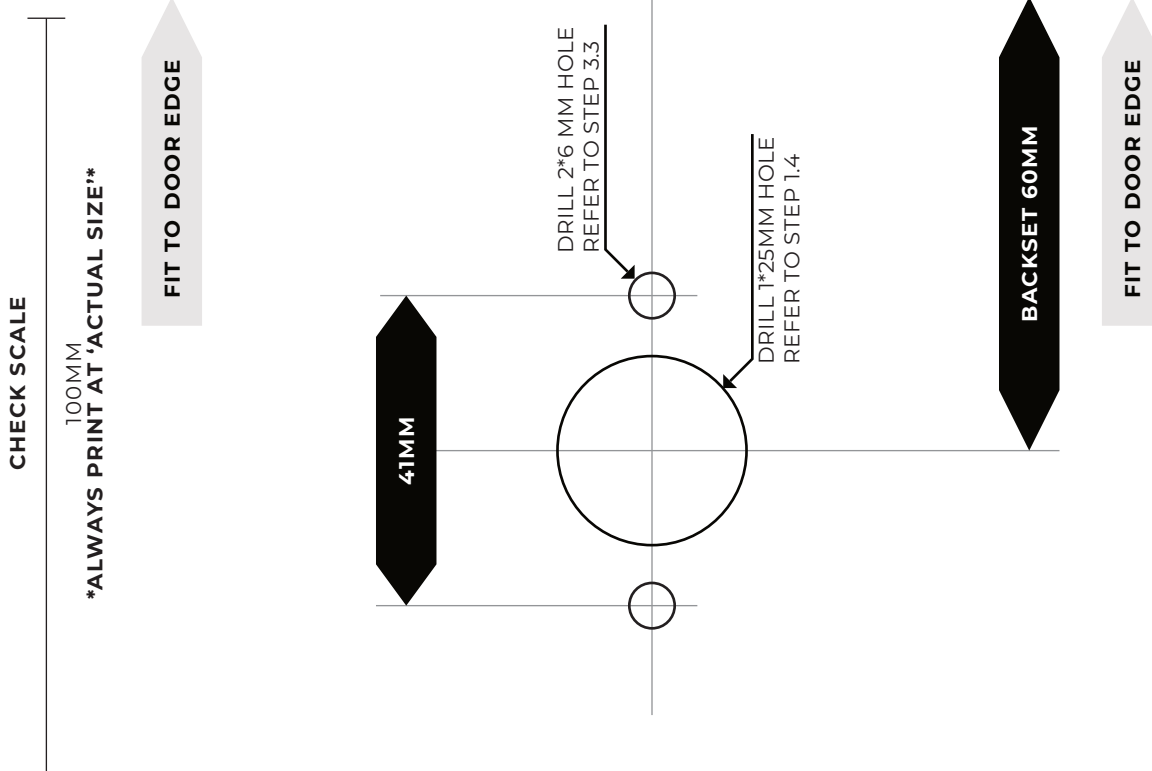

# TEMPLATE