

FORMA LEVER

TECH SPEC

SPECIFICATIONS

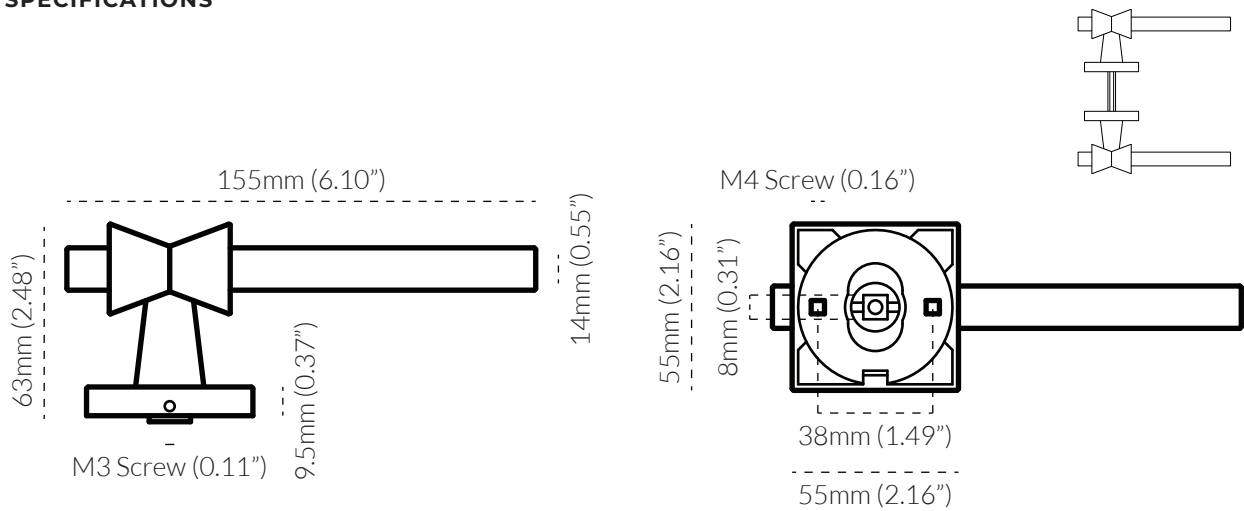
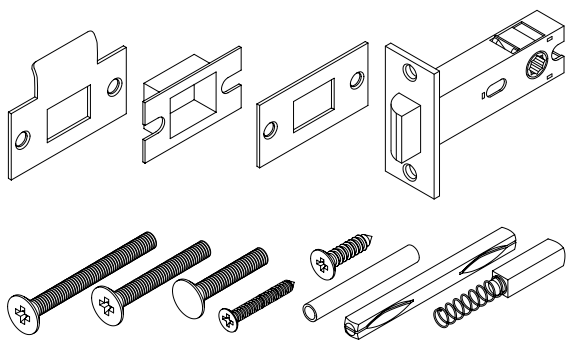

FINISH	SKU	FIXINGS ALSO INCLUDED
<ul style="list-style-type: none"> • Natural Brass • Tumbled Brass • Bronze • Polished Nickel • Brushed Nickel 	<ul style="list-style-type: none"> • 4230-US4 • 4230-TB • 4230-BR • 4230-PN • 4230-BN 	<ul style="list-style-type: none"> • 1x Striker Plate • 1x Latch Plate • 1x Latch Pocket • 1x Latch • 2x M4 * 15mm Screw • 2x M4 * 25mm Screw • 2x M4 * 35mm Screw • 4x 2ga Screw • 8x 1ga Self-tapping Screw • 2x M4 Screw Extension • 1x M5 Pin • 2x M5 Spring Pin 

CARE INSTRUCTIONS

Wipe with damp cloth and avoid using any chemicals.

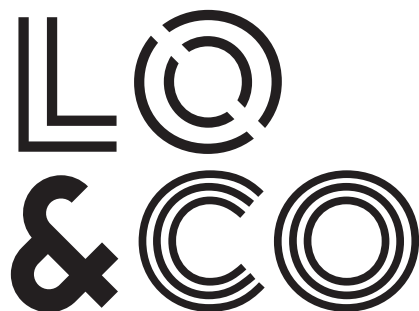

FORMA LEVER

INSTALLATION INSTRUCTIONS

STEP 3 - INSTALLING THE FITTING PLATES

- 3.1. Loosen the grub screw on each lever to remove and expose the fitting plates.
- 3.2. On the outward-facing side of the door, attach the two screw extensions to the fitting plate using the two flat-end 10mm M4 screws. Insert the fitting plate into the latch hub.
- 3.3. On the inward-facing side, align the second fitting plate and connect both sides by securing the 25mm M4 screws into the screw extensions.
 - For doors up to 45mm thick, use the included 35mm screws.
- 3.4. Ensure all fixings are fully tightened.

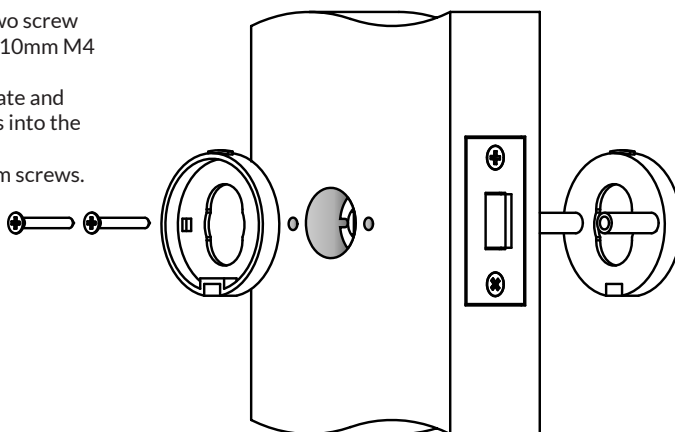

STEP 4 - FITTING THE LEVERS

- 4.1. Insert the spindle halves into the follower with the springs facing outwards toward the levers.
- 4.2. Position each lever with the grub screw hole facing downward. Fit the lever halves over the fitting plates and tighten the grub screw firmly until fully engaged.
- 4.3. Gently pull and operate each lever side to ensure it is secure and moves smoothly.

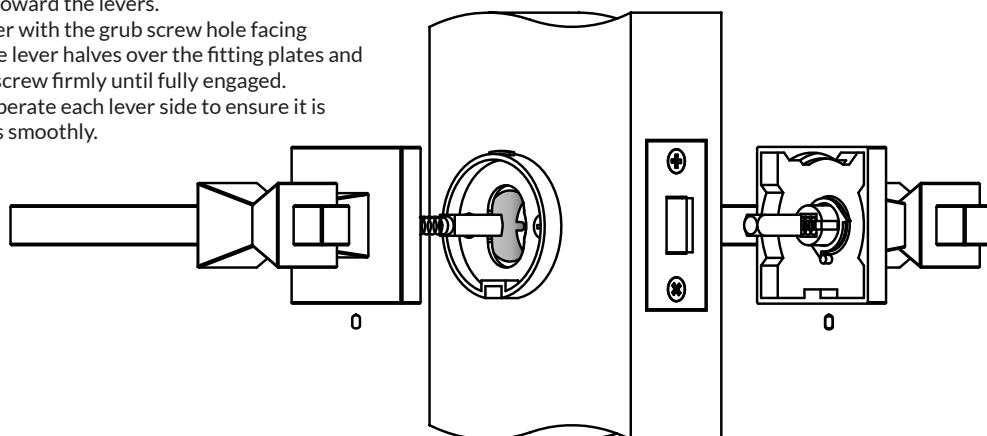

NOTES

- Use the included drilling template for accurate hole alignment.
- We recommend engaging a professional installer to fit your hardware for optimal results.



FORMA LEVER

INSTALLATION INSTRUCTIONS

STEP 5 - INSTALLING THE STRIKER PLATE

- 5.1. Close the door gently and mark where the latch contacts the door frame.
- 5.2. Position the striker plate over the marked area, ensuring the latch sits correctly within the opening. Trace the outline of the plate.
- 5.3. Drill a hole in the door frame at the latch mark using a drill bit that matches the latch bolt size.
- 5.4. Chisel a recess so the striker plate sits flush with the door frame.
- 5.5. Predrill the screw holes using an appropriately sized drill bit.
- 5.6. Secure the striker plate with the provided screws and ensure it is firmly in place.
- 5.7. Test the door by opening and closing it to check that the latch engages smoothly. Adjust if necessary.

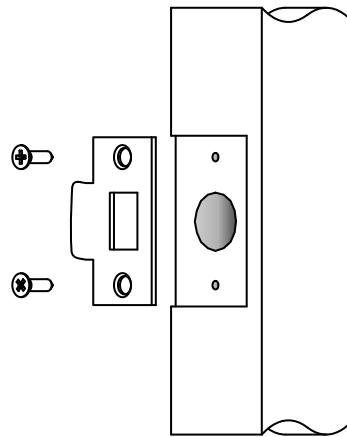

NOTES

- Use the included drilling template for accurate hole alignment.
- We recommend engaging a professional installer to fit your hardware for optimal results.



FORMA LEVER

INSTALLATION INSTRUCTIONS

*SUITS DOORS
32-45MM THICK

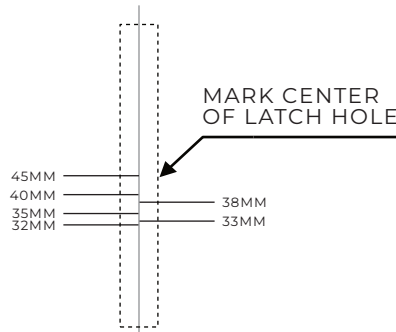

FOLD HERE

FOLD HERE

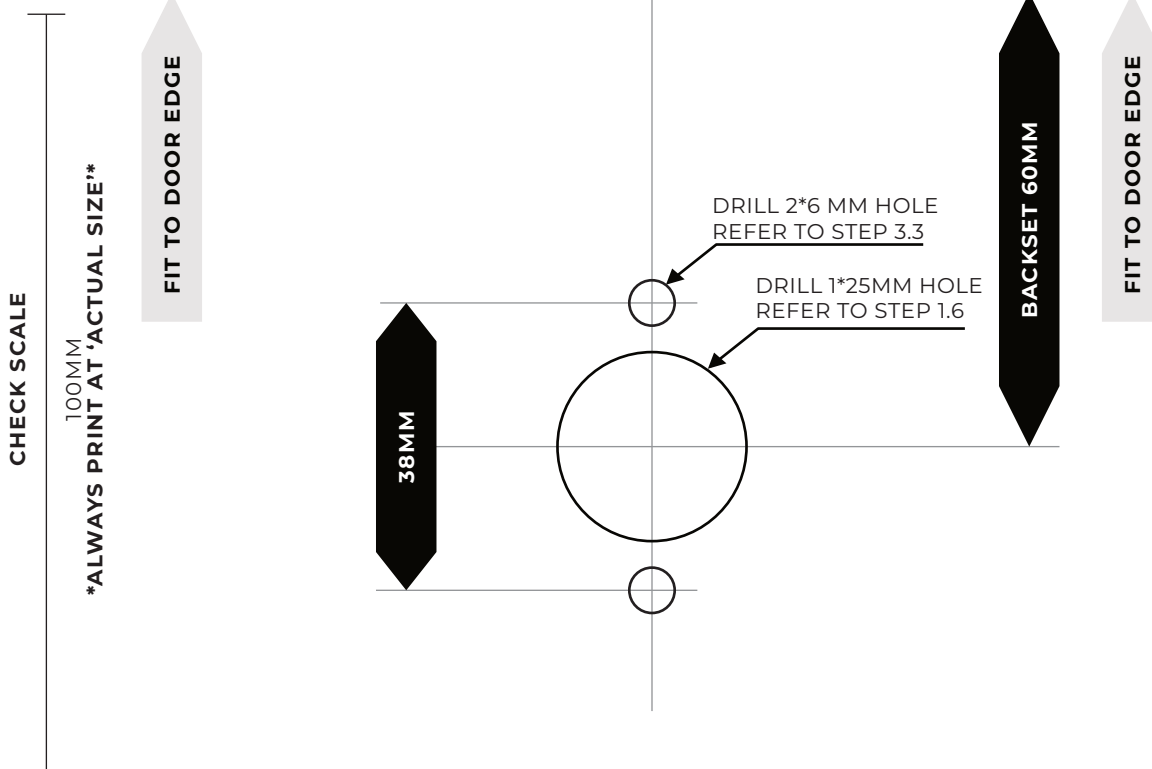

TEMPLATE