

DIMENSIONS			
A	B	C	THRU FIXING HOLE SIZE
300	360	240	8
400	460	340	8
500	560	440	8
600	660	540	8
700	760	640	8
800	860	740	8

Grub Screw

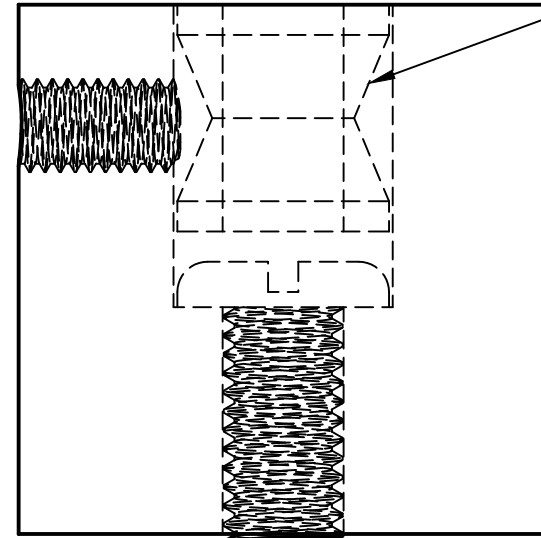
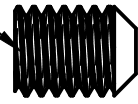

Brass Ferrule

Handle Stand

M8 Bolt

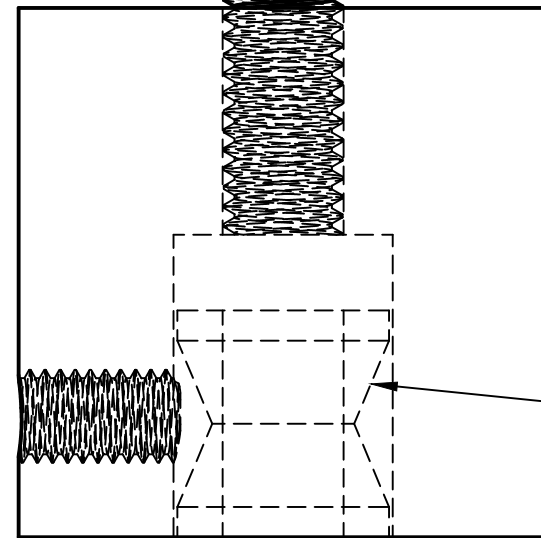

Threaded
Handle Stand

Brass Ferrule

Installation Instructions

IMPORTANT! Mark and drill door from both sides.

Cut bolt to required length. Allow 30mm longer than door thickness.

Screw stands together through door.

Place handle on stand, inserting Ferrules into stand.

Tighten Grub Screws



Drawing
Entrance Handle Fixing B2B

Date
2/02/2023

Scale
2:1

Installation Instructions
IMPORTANT! Mark and drill door from both sides.
Cut bolt to required length. Allow 15mm longer than door thickness.
Screw stands from behind to door.
Place handle on stand, inserting Ferrules into stand.
Tighten Grub Screws

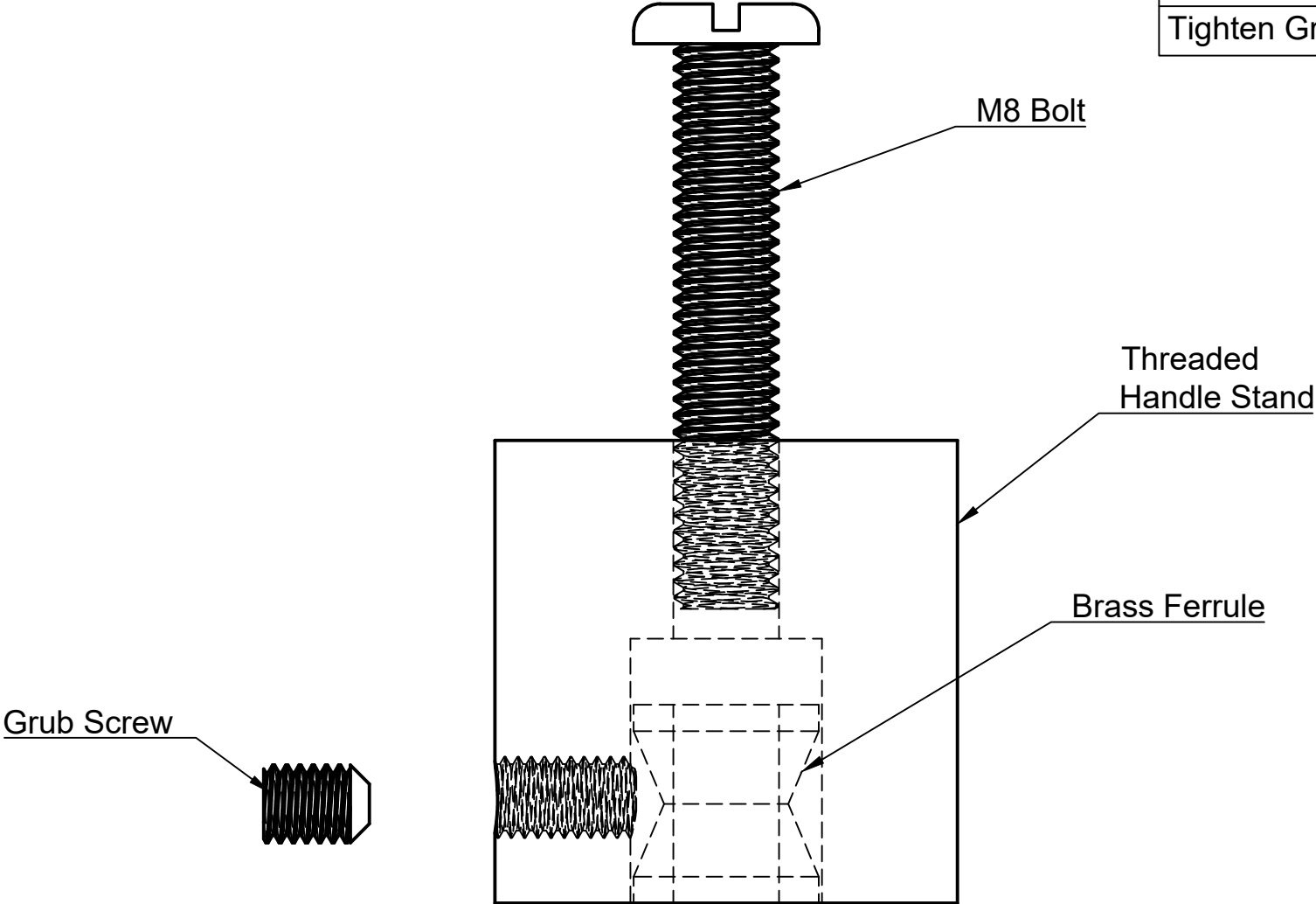

Drawing
Entrance Handle Rear Fixing
Date
2/02/2023
Scale
2:1

,QVWDOODWLRQ ,QVWUXFWLRQV
 Screw stand to door .
 Place handle on stand, inserting F
 Tighten Grub Screws

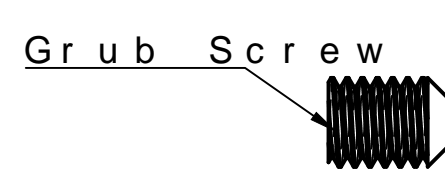

Grub Screw

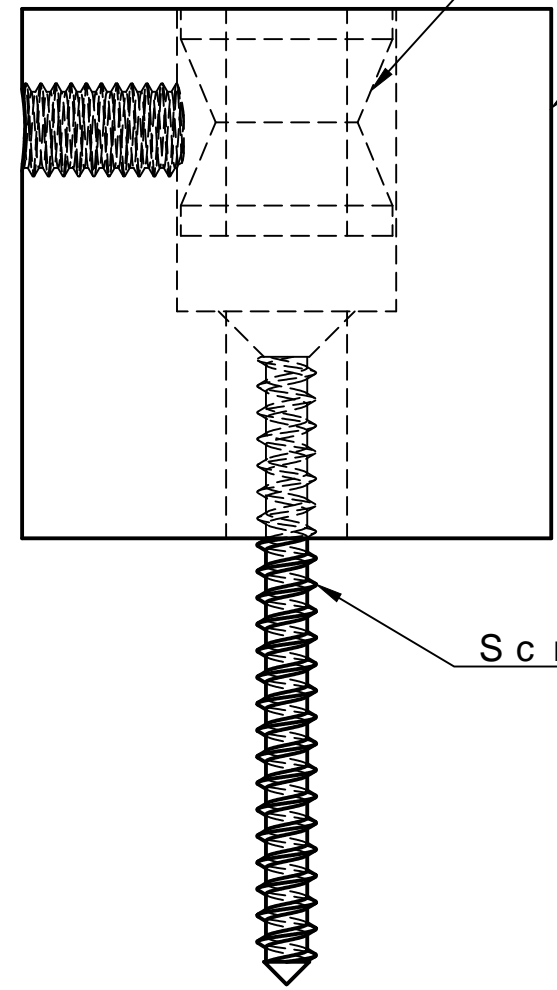

Ferrule

Handle Stand

Screw

	Drawing
	Entrance Handle
	Date
	2 / 02 / 2023
	Scale
	2 : 1